

OVENS

VULCAN**VC4G SERIES
SINGLE DECK GAS CONVECTION OVENS**

Model VC4GD
Shown on optional casters

**SPECIFICATIONS**

Single section, gas convection oven, Vulcan-Hart Model No. (VC4GD) (VC4GC). Stainless steel front, sides and top. Painted legs. Independently operated stainless steel doors with double pane windows. Non-sag insulation applied to the top, rear, sides, bottom and doors. Porcelain enamel on steel oven interior measures 29"w x 22¹/₈"d x 20"h. Two interior oven lights. Five nickel plated oven racks measure 28¹/₄" x 20¹/₂". Eleven position nickel plated rack guides with positive rack stops. One 50,000 BTU/hr. burner. Electronic spark igniter. Furnished with a two speed 1/2 H.P. oven blower-motor. Oven cool switch for rapid cool down. 120 volt, 60 Hz, 1 ph power supply required. 6' cord and plug. 8 amps total draw.

Exterior Dimensions:

40¹/₄"w x 41¹/₈"d (includes motor & door handles) 37³/₄"d (includes motor only) x 54³/₄"h on 23³/₄" legs, add 2" if on casters.

CSA design certified. NSF listed.

SPECIFY TYPE OF GAS WHEN ORDERING.
SPECIFY ALTITUDE WHEN ABOVE 2,000 FT.

- VC4GD** Solid state temperature controls adjust from 150° to 500°F. 60 minute timer with audible alarm.
- VC4GC** Computer controls with digital time and temperature readouts. 99-hour timer with audible alarm. Roast and Hold cycle. One hundred programmable menu selections. Shelf I.D. programming.

STANDARD FEATURES

- Stainless steel front, sides and top.
- Painted legs.
- Independently operated stainless steel doors with double pane windows.
- 50,000 BTU/hr. burner.
- Electronic spark igniter.
- 1/2 H.P. two speed oven blower-motor. 120/60/1 with 6' cord and plug. 8 amps total draw.
- Oven cool switch for rapid cool down.
- Porcelain enamel on steel oven interior.
- Five nickel plated oven racks with eleven rack positions.
- 3/4" rear gas connection with combination gas pressure regulator and safety solenoid system.
- One year limited parts and labor warranty.

OPTIONS

- Kosher friendly control package.
- Complete prison package.
 - Security screws only.
- Stainless steel legs.
- Casters.
- Simultaneous chain driven doors.
- 208V or 240V, 60 Hz, 1 ph, two speed, 1/2 H.P. blower motor.
- Control panel mounted on left side of oven.
- Second year extended limited parts and labor warranty.

ACCESSORIES

- Stainless steel open stand with adjustable rack supports, stainless steel shelf and choice of adjustable feet or casters.
- Oven/steamer accessory kit. Includes stainless steel marine edge top. Requires 8" legs in lieu of standard legs
- Stainless steel rear enclosure.
- Extra oven rack(s).
- Rack hanger.
- Stainless steel drip pan.
- Flexible gas hose with quick disconnect and restraining device. Consult price book for available sizes.
- Down draft flue diverter for direct vent connection.

VULCAN

a division of ITW Food Equipment Group LLC

P.O. Box 696 ■ Louisville, KY 40201 ■ Toll-free: 1-800-814-2028 ■ Local: 502-778-2791 ■ Quote & Order Fax: 1-800-444-0602



VC4G SERIES SINGLE DECK GAS CONVECTION OVENS

INSTALLATION INSTRUCTIONS

A combination gas pressure regulator and safety solenoid system is included in this unit. Natural gas is 5.0" W.C., Propane gas is 10.0" W.C.

An adequate ventilation system is required for commercial cooking equipment. Information may be obtained by writing to the National Fire Protection Association, Batterymarch Park, Quincy, MA 02289. When writing, refer to NFPA No. 96.

These units are manufactured for installation in accordance with ANSZ223.1 (latest edition), National Fuel Gas Code. Copies may be obtained from American Gas Association Inc.,

Accredited Standards Committee Z223, 400 N. Capitol St. NW, Washington, DC 20001 or the Secretary Standards Council, NFPA, 1 Batterymarch Park, Quincy, MA 02169-7471.

- | | | |
|----------------|-------------|-----------------|
| 4. Clearances: | Combustible | Non-combustible |
| Rear | 2" | 2" |
| Right Side | 4" | 4" |
| Left Side | 1" | 0" |

5. This appliance is manufactured for commercial installation only and is not intended for home use.

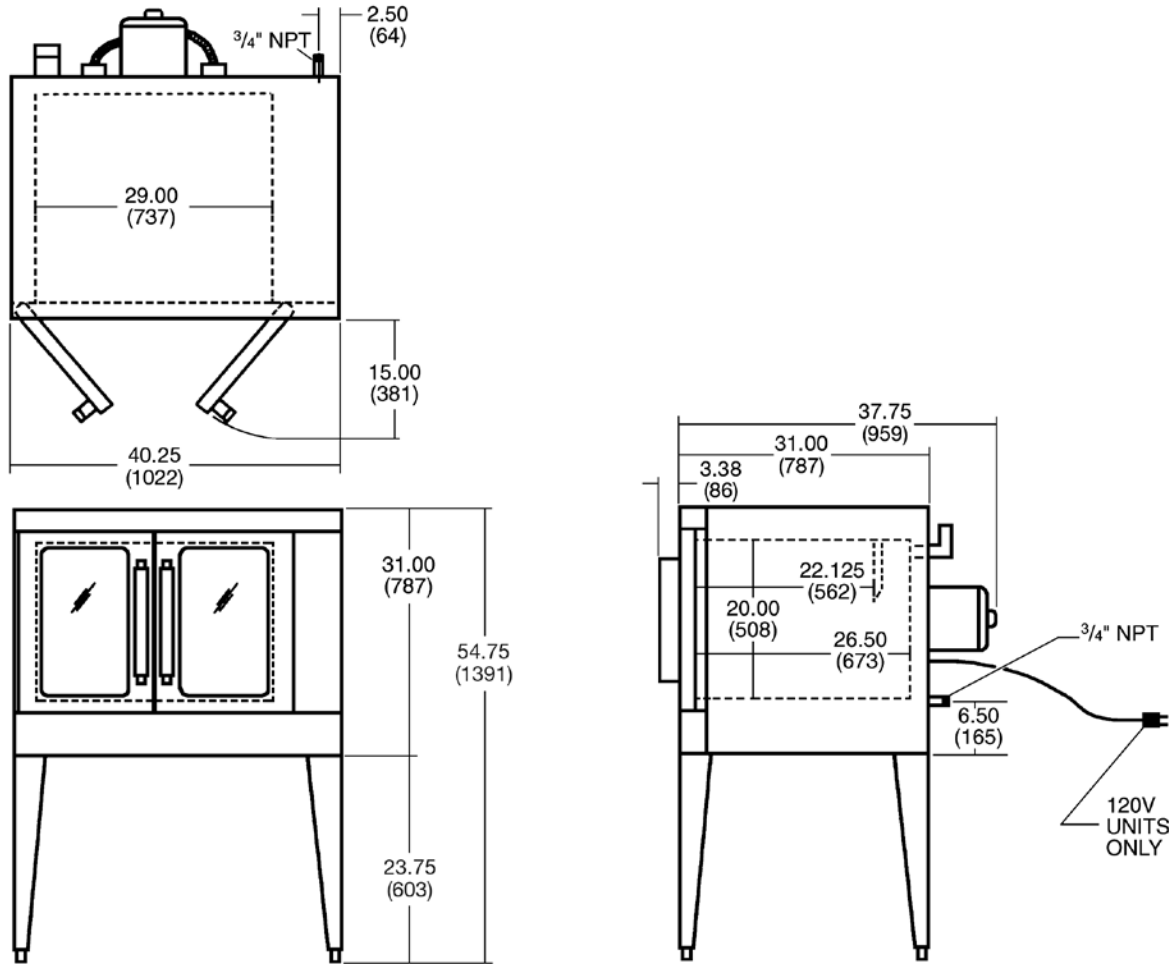

MODEL NO.	WIDTH	DEPTH (INCLUDES HANDLES)	HEIGHT	BTU/HR. PER OVEN	TOTAL BTU/HR.	ELECTRICAL	WEIGHT			
							WITH SKID & PACKAGING		WITHOUT SKID & PACKAGING	
							LBS.	KG	LBS.	KG
VC4G	40 1/4"	41 1/8"	54 3/4"	50,000	50,000	120/60/1	464	211	410	186



a division of ITW Food Equipment Group LLC

P.O. Box 696 ■ Louisville, KY 40201 ■ Toll-free: 1-800-814-2028 ■ Local: 502-778-2791 ■ Quote & Order Fax: 1-800-444-0602

NOTE: In line with its policy to continually improve its products, Vulcan reserves the right to change materials and specifications without notice.